



---

# ***DG-1000***

## ***Depth Gage***

# ***OPERATION MANUAL***

---



©2008 Gagemaker LP

OMDG-10009-01

**Contents****Introduction**

Technical Support	5
Product Information and Updates	5

**System Components**

DG-1000 Gage Component List	7
-----------------------------	---

**Setup Procedures**

Setting Up the DG-1000 Gage	9
-----------------------------	---

**Operating Procedures**

Inspecting Parts	13
------------------	----

**Care and Maintenance**

Replacing the Battery	16
Maintenance Tips	18
Warranty Information	18



Congratulations! Your decision to purchase a Gagemaker product above all others on the market demonstrates your confidence in our quality and workmanship.

To ensure the high performance and operation of our product, we urge you to use the included reference materials. They contain important information for proper setup and use of the equipment. Also, we recommend that you follow the care and maintenance tips in this manual to keep the equipment working in top condition.

If your questions have not been addressed in our reference materials, contact your local representative or a customer service representative at 713-472-7360.

## ***Introduction***

The DG-1000 series of gages inspects the location of internal and external shoulders and grooves from the face of the pin and box connectors or other datum surfaces. Three base types are available: standard, 12", and 20". These gages are available in ranges: 0" - 8", 0" - 12", 0" - 18", and 0" - 24".

The standard gage is supplied with a 7" extension arm and a 0° and 45° contact point holder. Longer extension arms and other contact point configurations and adapters are available upon request.

The DG-1000 gages do not require a setting standard. The gage is preset to zero on any flat surface and then applied to the product. Actual length measurements display on the gage's digital readout.

## **Technical Support**

Phone: 713-472-7360

Hours: Monday – Friday 8AM – 5PM (CST)

## **Product Information and Updates**

Visit our web site at: [www.gagemaker.com](http://www.gagemaker.com)



**System Components**

Take some time to become familiar with all the parts that make up the DG-1000 gage by reviewing the labeled diagram below. The part names are important for understanding the operating instructions.

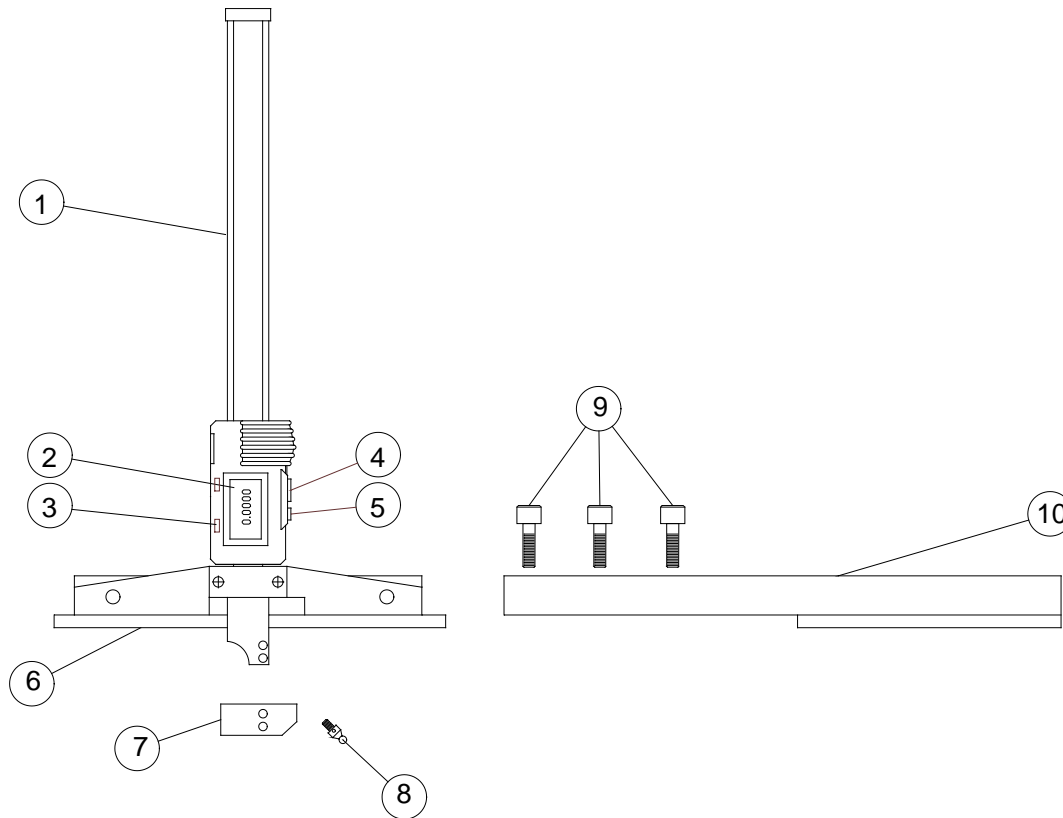

**Component List**

Item	Description	Qty	Item	Description	Qty
1	Gage shaft	1	6	Base plate assembly	1
2	Digital display	1	7	Contact point holder	1
3	IN/MM mode button	1	8	Contact point	1
4	ON/OFF button	1	9	Cap screws ((#10-32 X ¾"))	3
5	ZERO/ABS mode button	1	10	Extension arm	1



**Setup Procedures**

**Setting Up the DG-1000 Gage**

**Materials Needed:**

- DG-1000 depth gage
- Contact point
- 5/32" hex wrench

1. Determine if the setup of the contact point for the application is 0° or 45°.



**0 Degree Setup**

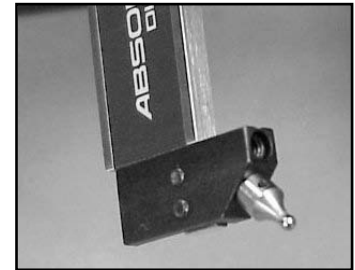

**45 Degree Setup**

2. **For 0° setup only:** Insert the contact point in the upper hole of the contact point holder and tighten.

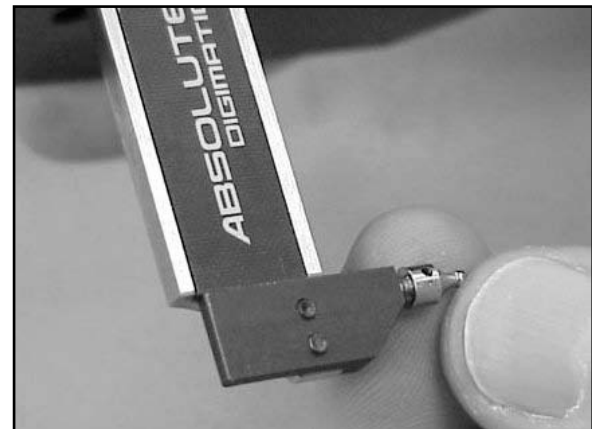

3. **For 45° setup only:** Insert the contact point in the lower hole of the contact point holder and tighten.

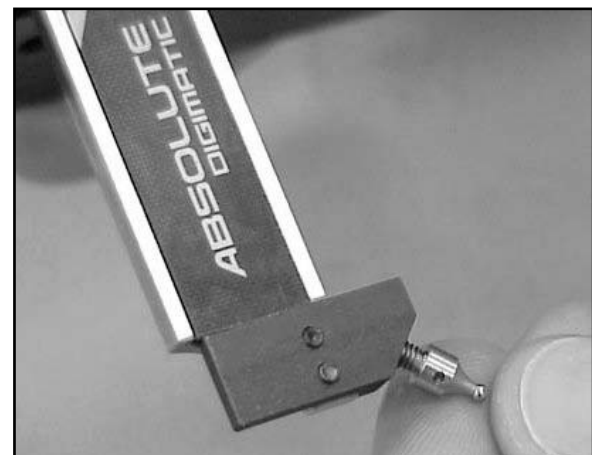

**Setting Up the DG-1000 Gage (continued)**

**Note:** If the extension arm is not properly positioned for taking measurements, you will need to switch the arm to the other side of the gage.

4. **To change the direction of the extension arm:** Using a 5/32" hex wrench, loosen the three cap screws in the arm.

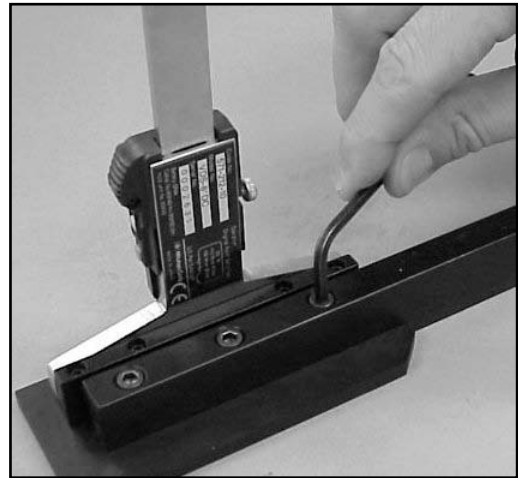

5. Remove the arm from the gage.

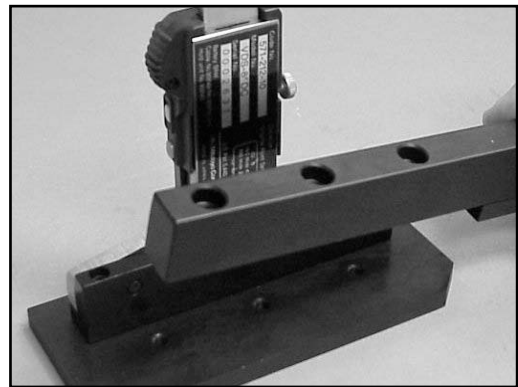

6. Rotate the arm and align the holes with base plate assembly.

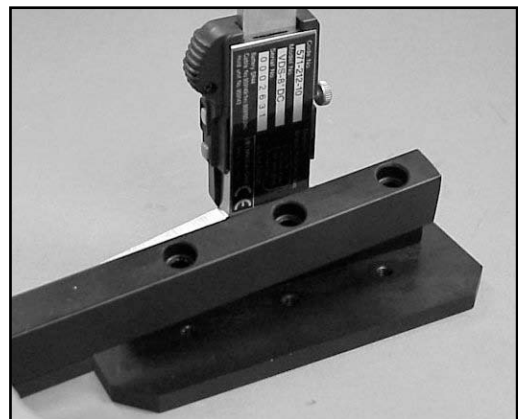

**Setting Up the DG-1000 Gage (continued)**

7. Insert and tighten the three cap screws.

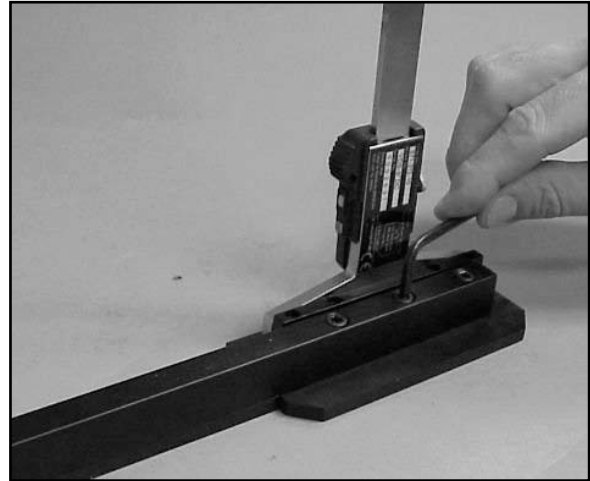

8. Press the IN/MM mode button to select inches or millimeters for the digital display.



9. **For 0° setup only:** While holding a flat surface against the base plate assembly, lower the contact point until it touches the surface. Proceed to step 11.

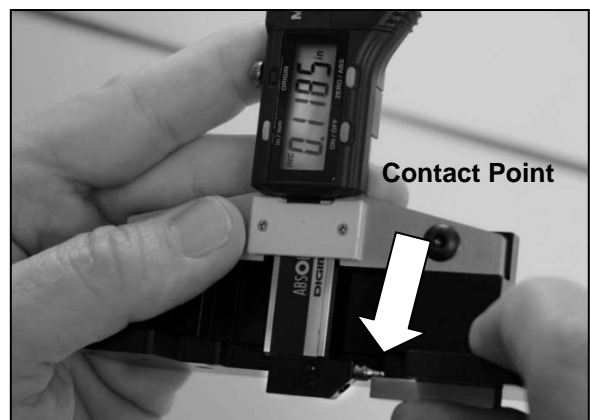

**Setting Up the DG-1000 Gage (continued)**

- 10. **For 45° setup only:** While holding the base plate assembly on a flat surface, lower the contact point until it touches the surface. Proceed to step 11.

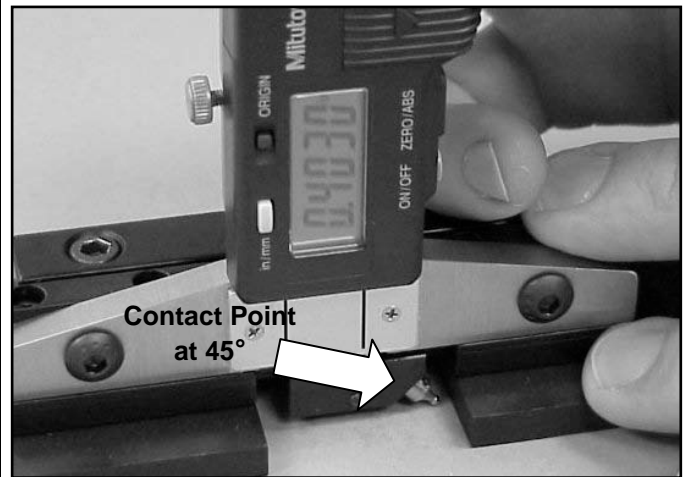

- 11. Press the ZERO/ABS mode button to zero the display.

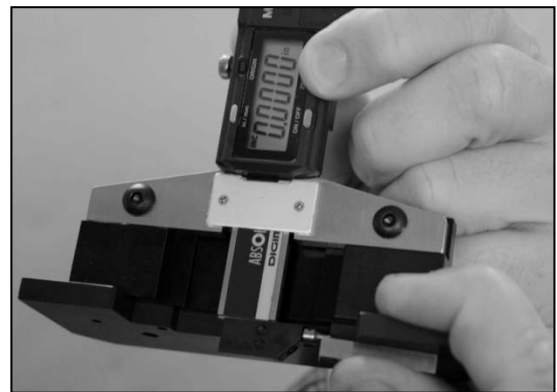

**0 Degree Setup**

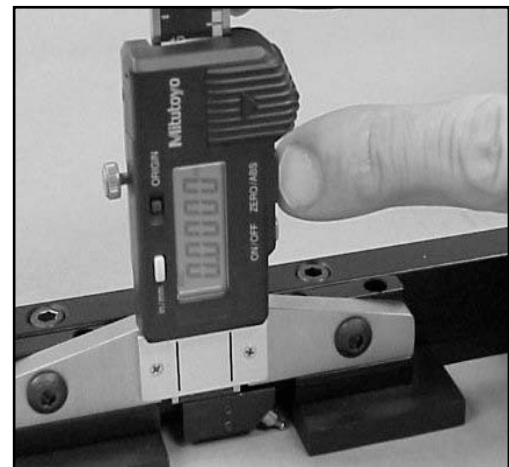

**45° Degree Setup**

## Operating Procedures

### Inspecting Parts

#### Materials Needed:

- DG-1000 gage
- Part
- Inspection report

1. Press the ON/OFF button to turn the gage on.

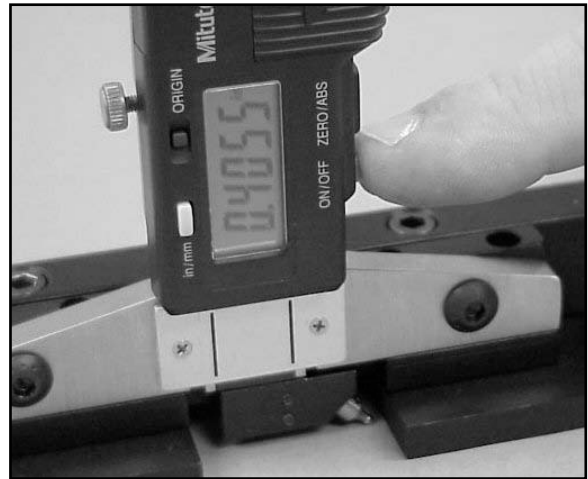

2. **For measuring internal parts:** Place the base plate assembly and extension arm of the gage across the part, so the contact point is located inside the part.



**Inspecting Parts (continued)**

3. **For 0° setup only:** Lower the gage shaft into the part and seat the contact point into the proper thread and pull the contact point back against top of groove. Review the illustration to note proper placement of the contact point.

4. Record any deviations on an inspection or calibration report.

5. **For 45° setup only:** Lower the gage shaft into the part and seat the contact point into the proper thread. Review the illustration to note proper placement of the contact point.

6. Record any deviations on an inspection or calibration report.

7. **For measuring external parts:** Place the base plate assembly and extension arm of the gage across the part, so the contact point is located outside the part.

8. Lower the gage shaft to seat the contact point into the proper thread.

9. Record any deviations on an inspection or calibration report.

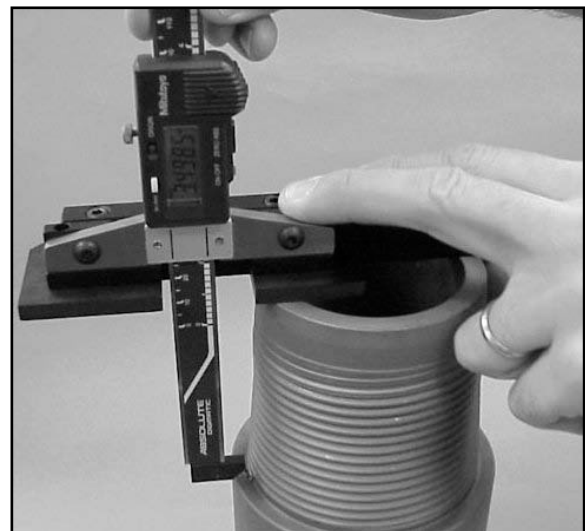
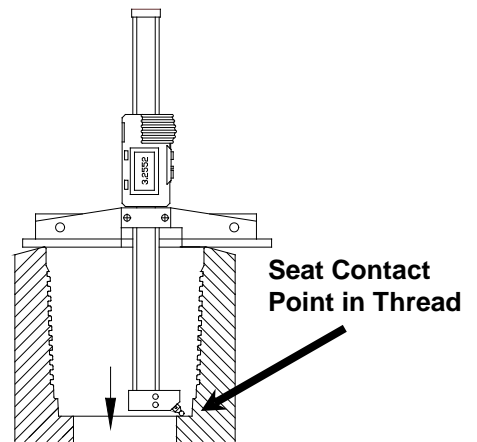
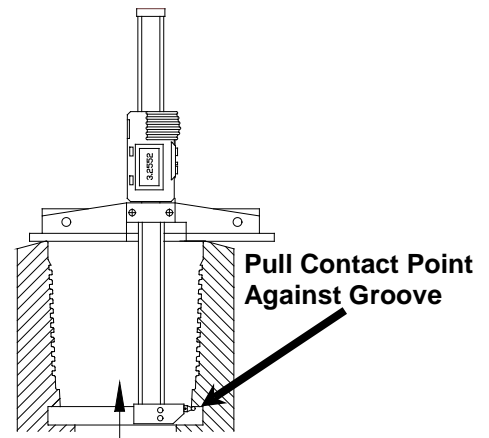

**Inspecting Parts (continued)**

10. Press the ON/OFF button to turn the gage off.

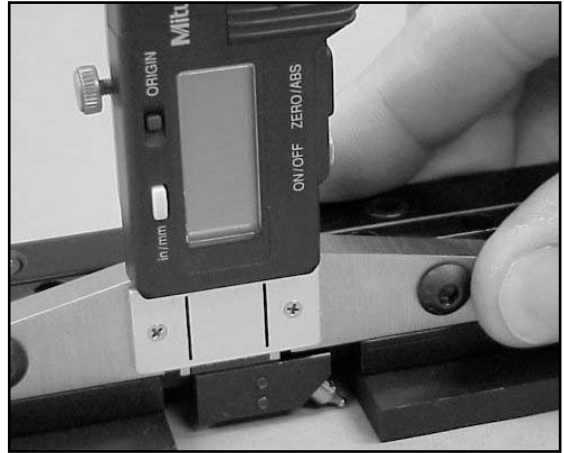

**Care and Maintenance**

**Replacing the Battery**

**Materials Needed:**

- DG-1000 gage
- Battery (Model No. SR-44)

1. Press the ON/OFF button to turn the gage off.

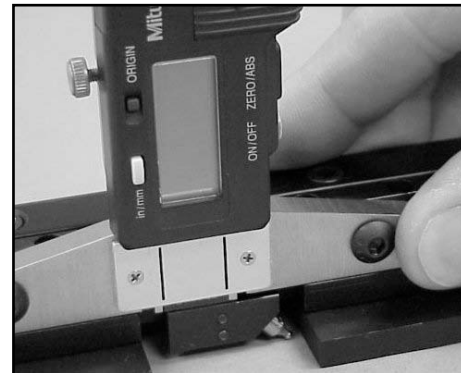

2. Remove the battery cover from the gage.



3. Remove the old battery and replace with a new battery (SR-44).



4. Replace the battery cover.

**Replacing the Battery (continued)**

5. Press the ON/OFF button to turn the gage on.

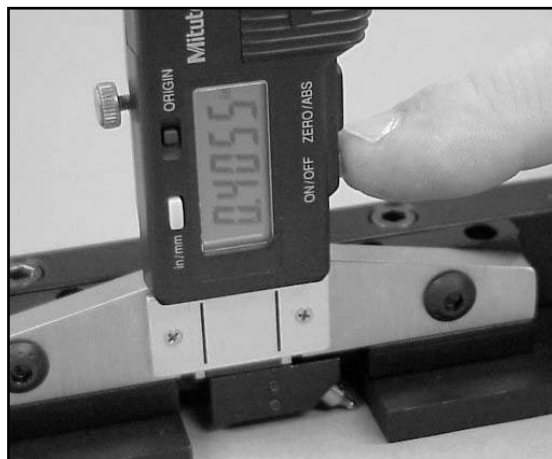

6. Press the ZERO/ABS mode button to zero the display.

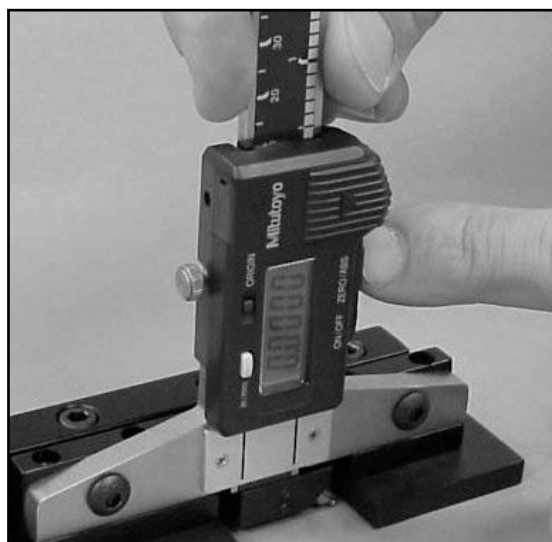

## **Maintenance Tips**

- Keep all unprotected metal surfaces coated with light oil.
- Avoid dropping the gage or subjecting it to any vibration or impact.
- Keep the gage dry and away from any machine coolant spray.
- Do not force the movement of any of the mechanical parts. The mechanics are designed to move freely.

## **Warranty Information**

GAGEMAKER warrants its products to be free from defects in material and workmanship for one year from the date of shipment. At our option, we will repair or replace any defective product upon return, prepaid, properly packed to our factory in Pasadena, Texas. This warranty applies to all products when used in a normal industrial environment. Any unauthorized tampering, misuse or neglect will make this warranty null and void. Under no circumstances will GAGEMAKER or any affiliate have any liabilities for loss or for any indirect or consequential damages. The foregoing warranties are in lieu of all other warranties expressed or implied, including but not limited to, the implied warranties of merchantability and fitness for a particular purpose.

NOTES:



# **GAGEMAKER**

Gagemaker, LP, P.O. Box 87709, Houston, Texas 77287-7709  
712 East Southmore Ave., Pasadena, Texas 77502  
Phone: 713-472-7360  
Fax: 713-472-7241  
Web site: [www.gagemaker.com](http://www.gagemaker.com)