

ET-7000

External Taper Gage

OPERATION MANUAL



©2008 Gagemaker LP

OMET70006-01

Contents**Introduction**

Technical Support	5
Product Information and Updates	5

System Components

Component List	7
----------------	---

Setup Procedures

Setting Up the ET-7000 Gage	9
-----------------------------	---

Operating Procedures

Inspecting Parts	11
------------------	----

Care and Maintenance

Replacing the Indicator	15
Maintenance Tips	17
Warranty Information	17

Congratulations! Your decision to purchase a Gagemaker product above all others on the market demonstrates your confidence in our quality and workmanship.

To ensure the high performance and operation of our product, we urge you to use the included reference materials. They contain important information for proper setup and use of the equipment. Also, we recommend that you follow the care and maintenance tips in this manual to keep the equipment working in top condition.

If your questions have not been addressed in our reference materials, contact your local representative or a customer service representative at 713-472-7360.

Introduction

The ET-7000 Series of gages inspect variations in connection taper of external threads ranging from 0"-24". Each model covers a specific range of connection sizes, making the ET-7000 gages very versatile and economical.

The ET-7000 gages use precision contact points that seat in the thread of the part during inspection. The gage's indicator reports actual measurement readings. Each set of contact points is interchangeable to allow measuring different thread forms. Contact point diameters are manufactured to tolerances of $\pm.0002$ ". The pitch of the thread and type of thread form determine the diameter of the contact points required for taking measurements (refer to the table for API Threads in the Setup Procedures section of this manual).

The ET-7000 gage requires no setting master to inspect parts. The contact points are seated in the threads of the part and the gage is properly positioned by sweeping to obtain the largest indicator reading. Taking measurements in two different locations along the length of the thread will detect any variations in taper.

Technical Support

Phone: 713-472-7360

Hours: Monday – Friday 8AM – 5PM (CST)

Product Information and Updates

Visit our web site at: www.gagemaker.com

System Components

Take some time to become familiar with all the parts that make up the ET-7000 gage by reviewing the labeled diagram below. The part names are important for understanding the operating instructions.

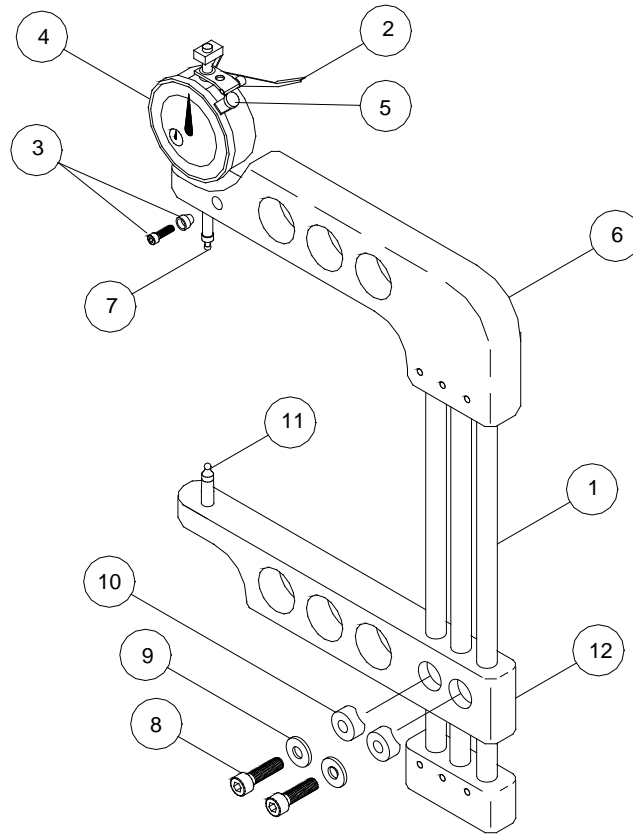

Component List

Item	Description	Qty	Item	Description	Qty
1	Gage body rails	3	7	Upper contact point	1
2	Indicator retraction lever	1	8	Locking cap screws	2
3	Indicator binder nut/cap screw	1	9	Washers	2
4	Indicator	1	10	Rail clamps	2
5	Indicator clamp	1	11	Lower contact point	1
6	Upper arm assembly		12	Lower arm assembly	1

Setup Procedures

Setting Up the ET-7000 Gage

Materials Needed:

- ET-7000 gage
- Contact points (2)
- Calipers
- Paper clip

Setting up the ET-7000 gage, involves installing the proper size contact points for the application (refer to the table below for selecting the proper model contact point for API threads).

API Threads			
Connection Type	Point Diameter	Pitch	Contact Point Model Number
Hughes Slim Line H-90	0.235"	3	T235
All Hughes H-90	0.200"	3 ½	T200
API Rotary Shouldered Connections	0.144"	4	T144
API Rotary Shouldered Connections	0.128"	4 ½	T128
API Rotary Shouldered Connections	0.115"	5	T115
API Rotary Shouldered Connections	0.096"	6	T096
Buttress Casing - Taper	0.090"	5	T090
API Tubing, Casing and Line Pipe	0.072"	8	T072
API Tubing and Line Pipe	0.057"	10	T057
API Line Pipe	0.050"	11 ½	T050

1. Determine the size of contact points to be used, by the pitch of the thread and type of thread form being inspected.
2. Using calipers, verify the size of the contact point.

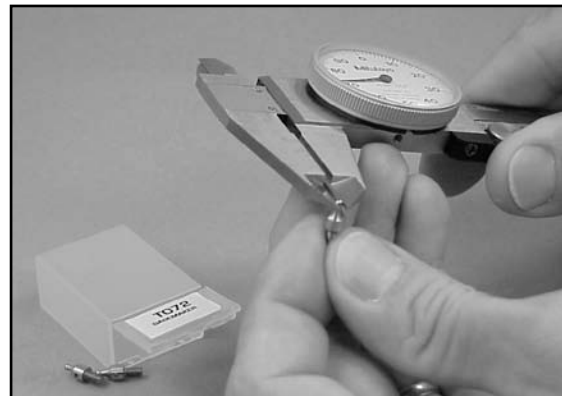

Setting up the ET-7000 Gage (continued)

3. Screw one contact point into the upper arm of the gage and the other contact point into the lower arm.



Do not use pliers to tighten the contact points, as damage may result.

4. To secure the contact points, open a paper clip and insert it into the hole in the contact point's shaft. Rotate, using moderate pressure, to tighten the contact point.

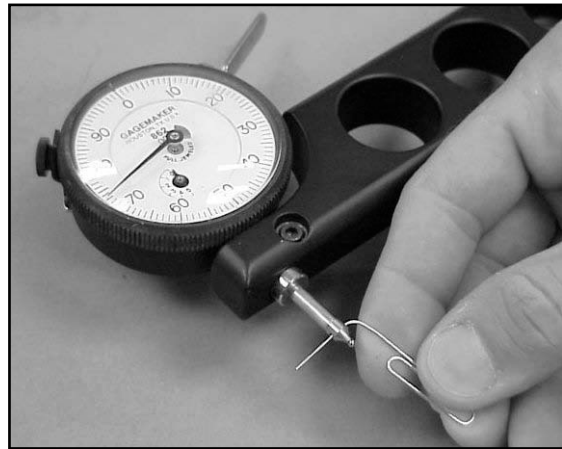

Operating Procedures

Inspecting Parts

Materials Needed:

- ET-7000 gage
- Part
- 3/16" hex wrench
- Marking pen
- Inspection report

Inspecting parts using the ET-7000 gage requires no setting master. However, inspection does involve marking two inspection locations with a marking pen, which are 1" apart on the connection. This process ensures that the contact points will be placed in the same helical path of the thread during inspection.

1. Using a marking pen, draw one full revolution on the threads of the part being measured, starting at the first perfect thread.



2. Mark another full revolution on the threads of the part one inch back from the first mark. For example, for a 8 pitch thread, count back 8 threads.

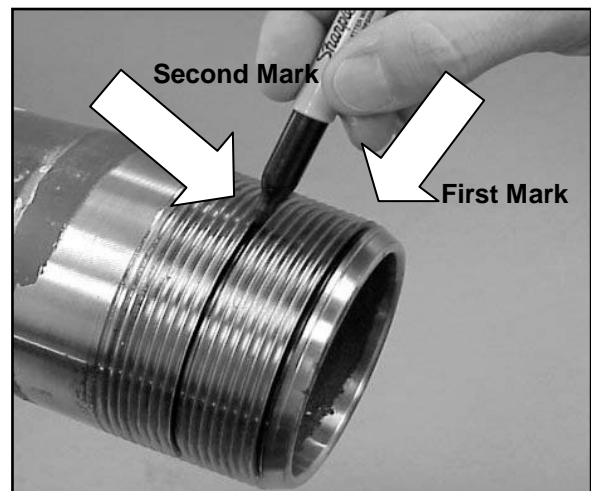

Inspecting Parts (continued)

3. Using a 3/16" hex wrench, loosen the capscrews on the lower arm.



4. Slide the lower arm of the ET-7000 gage open enough to fit over the part.

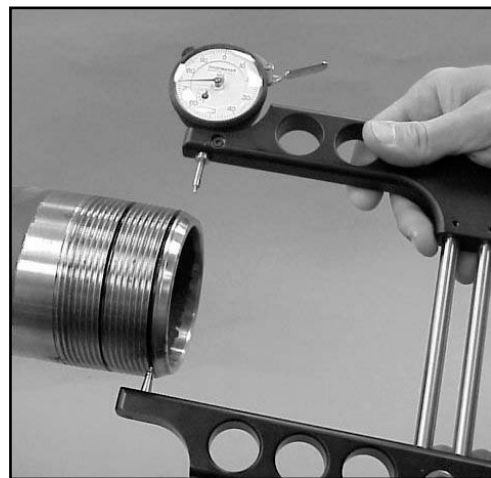

5. Seat the lower contact point into the first marked thread of the part.
6. Adjust the location of the lower arm until the upper contact point is seated in the same marked thread of the part.
7. Press the indicator retraction lever to remove the gage from the part.

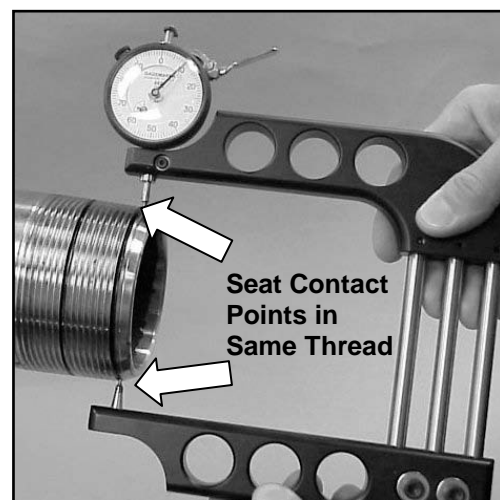

Inspecting Parts (continued)

- Continue to slide the lower arm until the indicator shows one revolution of preload. Tighten the lower arm cap screws.

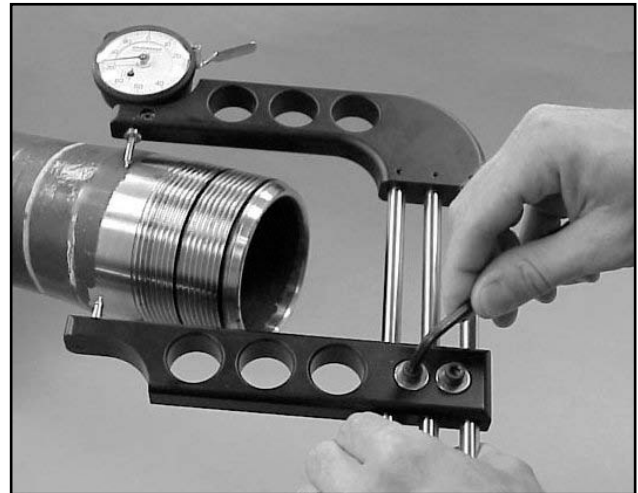

- Press the indicator retraction lever and seat the contact points in the first marked thread.
- Using the lower arm as a pivot, sweep the upper contact point side to side to locate the largest indicator reading.

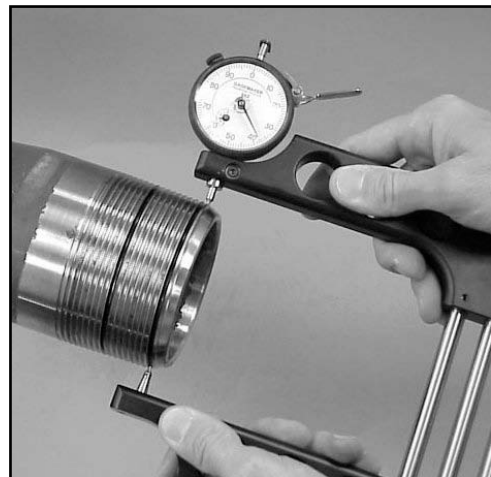

- Turn the indicator dial on the ET-7000 gage to align the needle with zero.

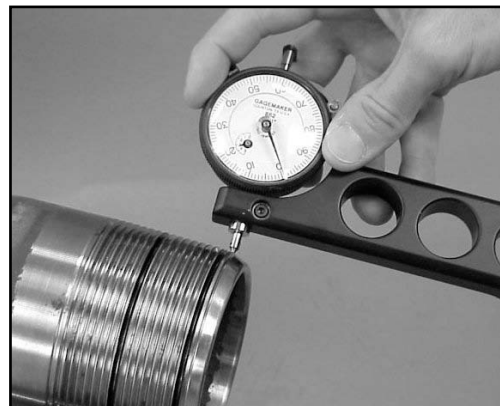

Inspecting Parts (continued)

12. Tighten the indicator clamp.
13. Record any deviations on an inspection or calibration report.

14. Remove the gage from the first marked thread and insert into the second marked thread.
15. Using the lower arm as a pivot, sweep the upper contact point side to side to locate the largest indicator reading.
16. Record any deviations on an inspection or calibration report.
17. Compare the readings with the taper specified in API Specification 5B.

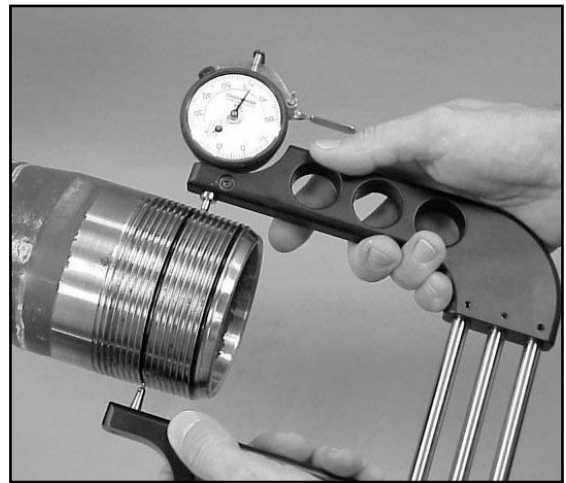
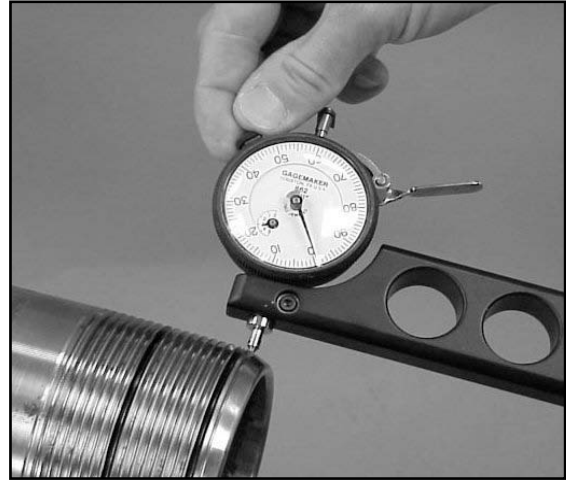

Care and Maintenance

Replacing the Indicator

Materials Needed:

- ET-7000 gage
- Indicator
- 7/64" hex wrench

1. Using a 7/64" hex wrench, loosen the cap screw on the upper arm assembly.



2. Remove the indicator from the upper arm.



Replacing the Indicator (continued)

3. Insert the new indicator into the upper arm and tighten the cap screw.



Maintenance Tips

- Keep all unprotected metal surfaces coated with light oil.
- Avoid dropping the gage or subjecting it to any vibration or impact.
- Keep the gage dry and away from any machine coolant spray.
- Do not force the movement of any of the mechanical parts. The mechanics are designed to move freely.
- Keep the indicator face clean.

Warranty Information

GAGEMAKER warrants its products to be free from defects in material and workmanship for one year from the date of shipment. At our option, we will repair or replace any defective product upon return of prepaid, properly packed to our factory in Pasadena, Texas. This warranty applies to all products when used in a normal industrial environment. Any unauthorized tampering, misuse or neglect will make this warranty null and void. Under no circumstances will GAGEMAKER or any affiliate have any liabilities for loss or for any indirect or consequential damages. The foregoing warranties are in lieu of all other warranties expressed or implied, including but not limited to, the implied warranties of merchantability and fitness for a particular purpose.



Gagemaker LP, P.O. Box 87709, Houston, Texas 77287-7709

712 East Southmore Ave., Pasadena, Texas 77502

Phone: 713-472-7360

Fax: 713-472-7241

Web site: www.gagemaker.com

Email: info@gagemaker.com