

# Profile Gages Tapered Thread Profile

# TP Series

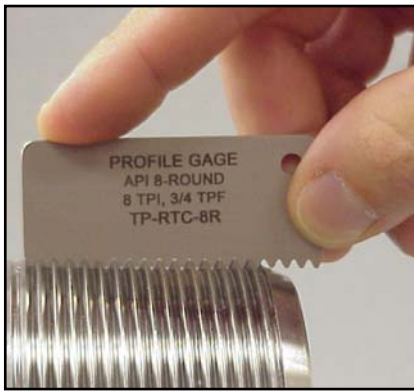

**TP Series**  
Thread profile gages quickly identify API thread forms



**TP Series**



**TP-JSS Series**  
(Jim's Sweet Stick)

### HOW TO ORDER

Select the profile gage model based on the type of connectors being measured.

The TP/TP-JSS Series of Tapered Thread Profile Gages are manufactured to tolerances of  $\pm .0002$ ", using EDM technology. These precision gages are ideal for quickly identifying each of the different tapered thread forms named in the API Std. 5B and Specification 7. Profile gages can also be used to perform a visual inspection of a thread form for detecting chipped inserts, stretched threads, wide first threads, or rolled over threads. Special profiles are available and quoted upon request.

### TP Series Thread Profile Gages

Model	TPF/TPI Thread Form	Connector Type
TP-415/O76	1.5" TPF, 4 TPI, V-0.076	2 $\frac{3}{8}$ " - 3 $\frac{1}{2}$ " P.A.C. Connections 2 $\frac{3}{8}$ " - 3 $\frac{1}{2}$ " American Open Hole
TP-RTC-8R	$\frac{3}{4}$ " TPF, 8 TPI, 8 Round	API 8-Round Casing, Tubing & Drill Pipe
TP-RTC-10R	$\frac{3}{4}$ " TPF, 10 TPI, 10 Round	API 10-Round Tubing
TP-8V	$\frac{3}{4}$ " TPF, 8 TPI, 8 V Thread	8V API Line Pipe, American Std. NPR
TP-11-1/2V	$\frac{3}{4}$ " TPF, 11 $\frac{1}{2}$ TPI, 11 $\frac{1}{2}$ V Thread	11 $\frac{1}{2}$ V API Line Pipe, American Std. NPT
TP-5BTC75-INT	$\frac{3}{4}$ " TPF, 5 TPI	API Buttress Casing, Internal, 4 $\frac{1}{2}$ " - 13 $\frac{3}{8}$ "
TP-5BTC75-EXT	$\frac{3}{4}$ " TPF, 5 TPI	API Buttress Casing, External, 4 $\frac{1}{2}$ " - 13 $\frac{3}{8}$ "
TP-5BTC1-INT	1" TPF, 5 TPI	API Buttress Casing, Internal, 16" - 20"
TP-5BTC1-EXT	1" TPF, 5 TPI	API Buttress Casing, External, 16" - 20"
TP-453-JSS	3" TPF, 5 TPI, V-0.040	2 $\frac{3}{8}$ " - 4 $\frac{1}{2}$ " API REG 3 $\frac{1}{2}$ ", 4 $\frac{1}{2}$ " API Full Hole
TP-542-JSS	2" TPF, 4 TPI, V-0.050	6 $\frac{5}{8}$ " API REG 5 $\frac{1}{2}$ " & 6 $\frac{5}{8}$ " API Full Hole
TP-543-JSS	3" TPF, 4 TPI, V-0.050	5 $\frac{1}{2}$ ", 7 $\frac{5}{8}$ ", & 8 $\frac{5}{8}$ " API REG
TP-6232-JSS	2" TPF, 6 TPI, V-0/032	2 $\frac{3}{8}$ " & 2 $\frac{7}{8}$ " Hughes External Flush
TP-642-JSS	2" TPF, 4 TPI, V-0.038R	4" API Full Hole, 2 $\frac{7}{8}$ "-5" Hughes Xtra Hole, 2 $\frac{3}{8}$ " - 4 $\frac{1}{2}$ " Hughes Slim Hole
TP-642-H- JSS <b>New</b>	2" TPF, 4 TPI, V-0.038R	2 $\frac{7}{8}$ " Hughes Xtra Hole, 2 $\frac{3}{8}$ " Hughes Slim Hole
TP-23-50-JSS	2" TPF, 4 TPI, V-0.038R	2 $\frac{3}{8}$ " - 6 $\frac{5}{8}$ " API INT Flush API Numbered Connectors #23 - #50
TP-56-77-JSS	3" TPF, 4 TPI, V-0.038R	API Numbered Connectors #56 - #77
TP-10-16-JSS	1.5" TPF, 6 TPI, V-0.055	API Numbered Connectors #10, #12, #13, #16 M.T. (Macaroni Tubing)
TP-076-JSS	1.5" TPF, 4 TPI, V-0.076	2 $\frac{3}{8}$ " - 4 $\frac{1}{2}$ " American Open Hole
TP-935-2-JSS	2" TPF, 3.5 TPI, H-90	3 $\frac{1}{2}$ " - 6 $\frac{5}{8}$ " Hughes H-90
TP-935-3-JSS	3" TPF, 3.5 TPI, H-90	7" - 8 $\frac{5}{8}$ " Hughes H-90
TP-931-1/4-JSS	1.25" TPF, 3TPI, H-90	2 $\frac{3}{8}$ " - 3 $\frac{1}{2}$ " Hughes Slim Line
TP-9060LS-JSS	Tool Grinding & Setting Gage	90° & 60° Threads, Tool Grinding & Setting Gage
TP-NPT-14	$\frac{3}{4}$ " TPF, 14 TPI	NPT Threads



The shoulder length distance will change per connection type.

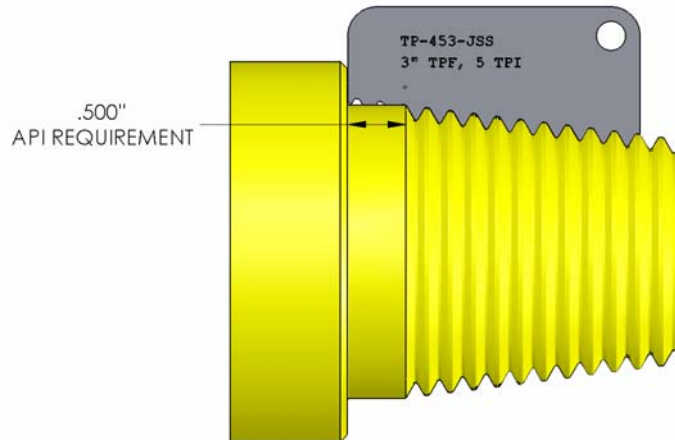

**The JSS style thread profile gage quickly locates the thread pull out location. Simply insert the template into the thread form and slide it around the connection until the front edge makes contact with the shoulder.**